

3-1-2011

Genetic Characterization of Porcine Epidemic Diarrhea Virus (PEDV) Isolates from Southern Vietnam during 2009-2010 Outbreaks

Do Tien Duy

Tat Toan Nguyen

Suphasawatt Puranaveja

Roongroje Thanawongnuwech

Follow this and additional works at: <https://digital.car.chula.ac.th/tjvm>



Part of the [Veterinary Medicine Commons](#)

Recommended Citation

Duy, Do Tien; Nguyen, Tat Toan; Puranaveja, Suphasawatt; and Thanawongnuwech, Roongroje (2011) "Genetic Characterization of Porcine Epidemic Diarrhea Virus (PEDV) Isolates from Southern Vietnam during 2009-2010 Outbreaks," *The Thai Journal of Veterinary Medicine*: Vol. 41: Iss. 1, Article 12. Available at: <https://digital.car.chula.ac.th/tjvm/vol41/iss1/12>

This Article is brought to you for free and open access by the Chulalongkorn Journal Online (CUJO) at Chula Digital Collections. It has been accepted for inclusion in The Thai Journal of Veterinary Medicine by an authorized editor of Chula Digital Collections. For more information, please contact ChulaDC@car.chula.ac.th.

Genetic Characterization of Porcine Epidemic Diarrhea Virus (PEDV) Isolates from Southern Vietnam during 2009-2010 Outbreaks

Do Tien Duy^{1,4} Nguyen Tat Toan² Suphasawatt Puranaveja³
Roongroje Thanawongnuwech^{1*}

Abstract

Porcine epidemic diarrhea virus (PEDV) spike (S) glycoprotein and membrane (M) glycoprotein genes are believed to have genetic variation. The heterogeneity in those genomic sequences has been reported and is known essentially for the diverse PEDV pathogenicity. Eight southern Vietnamese PEDVs collected from severe watery diarrhea piglets of the recent emerging outbreaks (2009-2010) were sequenced and analyzed. The results revealed high nucleotide homology of the partial S gene of the current isolates at 98.9-100% and 99.7-100% identity of the full M gene among these isolates despite dividing into two subclusters of different provincial origins. It should be noted that the Vietnamese PEDVs contained high differences on nucleotide sequence of partial S gene with other reference isolates in Europe (Br1/87, CV777) and in Korea (Spk1, Chinju99, DR13 and KNU-0801). The phylogenetic relationship of both partial S and M protein genes indicated that the current Vietnamese PEDVs were in the same cluster with the Chinese isolates (JS-2004-2 and DX), the Thai isolates (07NP01, 08NP02 and 08CB01) and the recent Korean isolates (KNU-0802 and CPF299). The results suggested that the current Vietnamese PEDV isolates might have originated from the same Chinese ancestor undergoing genetic variation and possibly forming a new PEDV genotype in Vietnam.

Keywords: phylogenetic analysis, pigs, porcine epidemic diarrhea virus, Vietnam

¹Department of Veterinary Pathology, Faculty of Veterinary Sciences, Chulalongkorn University, Henri-Dunant Rd, Pathumwan, Bangkok 10330, Thailand

²Department of Veterinary Internal Medicine and Pharmacology, Faculty of Animal Science and Veterinary Medicine, Nonglam University, Hochiminh city, Vietnam

³Veterinary Diagnostic Laboratory, Faculty of Veterinary Sciences, Chulalongkorn University, Henri-Dunant Rd, Pathumwan, Bangkok 10330, Thailand

⁴Department of Veterinary Microbiology and Infectious Diseases, Faculty of Animal Science and Veterinary Medicine, Nonglam University, Hochiminh city, Vietnam

*Corresponding author E-mail: Roongroje.T@chula.ac.th

บทคัดย่อ

ลักษณะทางพันธุกรรมของไวรัสพีอีดีที่แยกได้จากภาคใต้ของประเทศเวียดนามระหว่างการระบาดในปี ค.ศ. 2009-2010

โด เทียน ดุย^{1,4} เหงียน ทัด โธน² ศุภสวัสดิ์ บูรณเวช³ รุ่งโรจน์ ธนาวงษ์นุเวช^{1*}

ยีนของโปรตีนสไปค์และโปรตีนเมมเบรนของไวรัสพีอีดีเป็นยีนที่มีความหลากหลายทางพันธุกรรมซึ่งจะมีความแตกต่างกันในแต่ละพื้นที่ มีรายงานว่า ลำดับทางพันธุกรรมของจีโนมที่ต่างกันภายในยีนดังกล่าวมีความเกี่ยวข้องกับพยาธิกำเนิดของโรค เมื่อทำการถอดรหัสและวิเคราะห์พันธุกรรมของไวรัสพีอีดีจำนวน 8 ตัวอย่าง ซึ่งแยกได้จากลูกสุกรในฟาร์มทางใต้ของประเทศเวียดนามที่แสดงอาการท้องเสียในช่วงที่มีการระบาดของโรคพีอีดีระหว่าง ปี ค.ศ. 2009-2010 พบว่าบางส่วนของยีนสไปค์และทั้งหมดของยีนเมมเบรนของไวรัสพีอีดีดังกล่าว มีความเหมือนกันร้อยละ 98.9-100 และ 99.7-100 ตามลำดับ โดยสามารถแบ่งออกเป็น 2 กลุ่มย่อยตามจังหวัดที่พบเชื้อซึ่งมีความแตกต่างจากไวรัสพีอีดีที่พบในทวีปยุโรป (Br1/87 และ CV777) และประเทศเกาหลี (spk1, Chinju99, DR13 และ KNU-0801) ผลการวิเคราะห์ความสัมพันธ์ของลำดับนิวคลีโอไทด์ของเชื้อแบบแผนภูมิต้นไม้พบว่าเชื้อที่แยกได้จากการศึกษานี้จัดอยู่ในกลุ่มเดียวกับเชื้อไวรัสที่ก่อโรคปัจจุบันในประเทศจีน (JS-2004-2 และ DX) ประเทศไทย (07NP01, 08NP02 และ 08CB01) และประเทศเกาหลี (KNU-0802 และ CPF299) จากผลการศึกษาพบว่า ไวรัสพีอีดีที่ระบาดในประเทศเวียดนาม มีความเป็นไปได้ที่จะมีสายวิวัฒนาการมาจากไวรัสในประเทศจีน โดยมีการเปลี่ยนแปลงลักษณะทางพันธุกรรมดังกล่าวอาจเกิดขึ้นหลังจากการระบาดมาระยะเวลาหนึ่ง จนพัฒนาเป็นไวรัสพีอีดีสายพันธุ์ใหม่ในประเทศเวียดนาม

คำสำคัญ: phylogenetic analysis สุกร porcine epidemic diarrhea virus เวียดนาม

¹ ภาควิชาพยาธิวิทยา คณะสัตวแพทยศาสตร์ จุฬาลงกรณ์มหาวิทยาลัย ปทุมวัน กรุงเทพฯ 10330

² Department of Veterinary Internal Medicine and Pharmacology, Faculty of Animal Science and Veterinary Medicine, Nonglam University, Hochiminh city, Vietnam

³ หน่วยชันสูตรโรคสัตว์ คณะสัตวแพทยศาสตร์ จุฬาลงกรณ์มหาวิทยาลัย ปทุมวัน กรุงเทพฯ 10330

⁴ Department of Veterinary Microbiology and Infectious Diseases, Faculty of Animal Science and Veterinary Medicine, Nonglam University, Hochiminh city, Vietnam

*ผู้รับผิดชอบบทความ E-mail: Roongroje.T@chula.ac.th

Introduction

Porcine epidemic diarrhea (PED) is a contagious disease caused by a Coronavirus called porcine epidemic diarrhea virus (PEDV) producing acute enteritis and fatal watery diarrhea with high mortality particularly in suckling pigs up to 90% (Pensaert and Yeo, 2006). PED was first identified in England in 1971 and has currently become a problematic disease causing massive economic losses in many countries, mainly, in Europe and Asia (Pensaert and Yeo, 2006; Park et al., 2007b; Chen et al., 2008; Puranaveja et al., 2009). Heterogeneity in genomic sequences has been reported and is known essentially as the cause for the diverse PED pathogenicity. A number of molecular investigations have been performed and revealed low to high variation of nucleotide sequences of PEDV, especially

in the S glycoprotein gene (Duarte and Laude., 1994; Kocherhans et al., 2001; Yeo et al., 2003; Kang et al., 2005; Park et al., 2007b; Puranaveja et al., 2009; Lee et al., 2010). Phylogenetic analysis comparing PEDVs from various countries demonstrated that PEDVs were classified into three distinct groups based on nucleotide homology of the partial S gene and M gene (Park et al., 2007b; Chen et al., 2008; Puranaveja et al., 2009; Lee et al., 2010).

In early 2009, emerging PED outbreaks confirmed by pathological features and RT-PCR in most of the southern provinces of Vietnam caused massive economic losses in the swine industry (unpublished data). The disease investigation revealed that acute diarrhea syndrome occurred in all age groups of pigs. The affected animals manifested acute watery diarrhea condition and finally recovered mostly in adult animals. Suckling piglets suffered from severe watery diarrhea, dehydration and died

within a few days. Morbidity in suckling pigs reached 100% and mortality among provinces ranged from 65% to 91%. Therefore, the objective of this study was to genetically characterize the current PEDV isolates for elucidation of the epidemiologic relationship among PEDV isolates during the 2009-2010 outbreaks in southern Vietnam.

Materials and Methods

Sample collection: Total 8 PEDV isolates taken from 3-10 day-old piglets suffering from watery diarrhea and dehydration on five different affected farms of three provinces in southern Vietnam were included in this study.

RNA isolation: Small intestinal samples were homogenized by adding PBS to 10% suspension, centrifuged at 3000 rpm for 10-15 min at 4°C. The supernatant of 1-3 ml was collected into the sterile centrifuged tubes using for total RNA isolation according to the protocol of the commercial kit's instruction (Promega, Madison, WI, USA).

RT-PCR: Two different genomic regions were amplified, 651 bp fragment of partial S glycoprotein gene and 715 bp fragment of full M gene, by using the two pairs of primers based on previous publication (Park et al., 2007^b; Chen et al., 2008). Briefly, nucleotide strands of the partial S gene primers are 5'-TTCTGAGTCACGAACAGCCA-3' (PS1, forward), 5'-CATATGCAGCCTGCTCTGAA-3' (PS2, backward) and of M gene primers, 5'-CCCCAGTACTGTTA TTGACGTATAAAC-3' (PM1, forward), 5'-GTTTAC ACTAAATGAAGCACTTTC-3' (PM2, backward),

respectively. One tube RT-PCR reaction was used to amplify partial S and M glycoprotein genes of PEDV (AccessQuick™, Promega, Madison, USA). Exactly, 4 µl RNA template was mixed with a reaction mixture, which contained 10 µl of 2x AccessQuick™ Master Mix (Promega, Madison, WI, USA), 1 µl of each specific primer (10 µM), 0.5 µl of MgCl₂ (25 µM), 0.5 µl and AMV reverse transcriptase (10 u/µl). Then, 8 µl nuclease-free water was added to reaching the total volume reaction of 25 µl. The RT-PCR reactions were run in a Thermal hybrid PCR machine (USA), divided into three stages. Firstly, reverse transcription reaction incubated at 48°C for 45 min to make the first strand cDNA synthesis. Then, the second strand cDNA synthesis and PCR amplification were denatured at 95°C for 2 min (01 cycle), repeatedly denatured at 94°C for 30 sec for 30 cycles, annealed at 53°C for 60 sec and extended at 72°C for 60 sec. Additional step is the final extension at 72°C for 5 min. The last stage is to hold the PCR products at 4°C. Analyzing the PCR products by agarose gel electrophoresis of 1.5% was readily visible by UV transillumination of an ethidium bromide-stained gel.

Sequencing: Purified PCR products corresponding to the partial S glycoprotein gene and full M gene were sequenced by 1st BASE Pte Ltd (Singapore). All sequencing reactions were carried out in duplicate and all sequences was determined by sequencing both strands (forward and backward strands). The sequencing process used BigDye Terminator v3.1 cycle sequencing kit performed in 96-well plate (BigDye® Terminator v3.1 Cycle Sequencing Kit's protocol).

Table 1 Sources of viruses

Order	Isolates	Countries and year of sampling	Accession number	References
1	CV777 ^{S/M}	Belgium, 1977	AF353511.1	Kocherhans et al., 2001
2	Br1/87 ^{S/M}	Britain, 1987	Z25483/Z24733.1	Duarte and Laude, 1994
3	JS-2004-2 ^{S/M}	China, 2004	AY653204.1/ Y653205.1	Unpublished
4	LZC ^M	China, 2006	EF185992.1	Unpublished
5	DX ^{S/M}	China, 2007	EU031893.1	Unpublished
6	CHIMT06 ^M	China, 2006	EU033965.1	Chen et al., 2010
7	Spk1 ^S	Korea, 2002	AF500215.1	Kang et al., 2005
8	Chinju99 ^{S/M}	Korea, 1999	AY167585.1	Yeo et al., 2003
9	DR13 ^S	Korea, 2006	DQ462404.2	Park et al., 2007 ^a
10	KNU-0801 ^S	Korea, 2008	GU180142.1	Lee et al., 2010
11	KNU-0802 ^S	Korea, 2008	GU180143.1	Lee et al., 2010
12	M1763 ^M	Korea, 2003	FJ687455.1	Unpublished
13	CPF299 ^M	Korea, 2007	FJ687467.1	Unpublished
14	KPEDV-09 ^M	Korea, 1997	AF015888.1	Kweon et al., 1999
15	07NP01 ^{S/M}	Thailand, 2007	FJ196196.1	Puranaveja et al., 2009
16	08NP02 ^{S/M}	Thailand, 2008	FJ196204.1	Puranaveja et al., 2009
17	08CB01 ^S	Thailand, 2008	FJ196197.1	Puranaveja et al., 2009
18	KU06RB08 ^M	Thailand, 2008	FJ196194.1	Puranaveja et al., 2009
19	VN92 ^{S/M}	Vietnam, 2009	HQ883485/HQ883479	In this study
20	VN94 ^S	Vietnam, 2009	HQ883486	In this study
21	VN97 ^S	Vietnam, 2010	HQ883487	In this study
22	VN103 ^{S/M}	Vietnam, 2010	HQ883488/HQ883480	In this study
23	VN109 ^{S/M}	Vietnam, 2010	HQ883489/HQ883481	In this study
24	VN112 ^{S/M}	Vietnam, 2010	HQ883490/HQ883482	In this study
25	VN116 ^{S/M}	Vietnam, 2010	HQ883491/HQ883483	In this study
26	VN122 ^{S/M}	Vietnam, 2010	HQ883492/HQ883484	In this study

^SIsolate used for sequence analysis of the partial S gene; ^MIsolate used for sequence analysis of the full M gene

Sequencing analysis: Nucleotide sequences of the current Vietnamese PEDV isolates and other selected isolates presented on Table 1 (Genbank: <http://www.ncbi.nlm.nih.gov>) were edited, aligned

and analyzed with Chromas 2.33, Bioedit v7.0.5.3, and ClustalX 2.0.11 program. The phylogenetic trees and deduced amino acid sequences were then generated based on the Maximum likelihood method (Saitou

and Nei, 1993) with the MEGA 5.0. The relative support for each branch and the bootstrap value of 1000 replicates were computed (Tamura et al., 2007).

Results

Eight southern Vietnamese PEDVs were collected from recent PEDV-affected commercial swine farms (2009-2010) in three different provinces. These isolates were confirmed by one-step RT-PCR amplification to recognize the specific products of partial S gene and full M gene. They were sequenced and named VN92S1, VN94S2, VN97S3, VN103S4, VN109S5, VN112S6, VN116S7, VN122S8 for partial S gene analysis and VN92M1, VN9103M2, VN109M3, VN112M4, VN116M5, VN122M6 for full M gene analysis.

Sequence homology

Partial S gene: The pairwise alignment of the southern Vietnamese PEDV isolates showed high nucleotide homology to each other (98.9-100%). VN92S1 had minor different nucleotide and encoded amino acid sequence with other isolates (VN94S2, VN97S3, VN103S4, VN109S5, VN112S6, VN116S7, VN122S8) at 98.9% and 97.3% identity, respectively. It should be noted that the current PEDV isolates contained variable differences on nucleotide sequences of the partial S gene with other reference isolates (Table 2) sharing 95.6-96.4% nucleotide identity with the European prototypes (CV777, Br1/87) and 91.4-97.8% identity with the Korean isolates (Chinju99, Spk1, DR13, KNU-0801, KNU-0802). Interestingly, the Vietnamese isolates shared high nucleotide homology with the Chinese isolates (JS-2004-2, DX) and the Thai isolates (07NP01, 08NP02, 08CB01) at 97.7-98.5% and 98.8-99.5%, respectively. The average of nucleotide sequence identity of the current Vietnamese PEDVs revealed high correlation together with those of neighboring countries such as the Chinese isolate (JS-2004-2) at

98.4%, the Thai isolates at 99.35% and the recent Korean isolate (KNU-0802) at 97.51% (Table 3).

For deduced amino acid sequence analyses of the partial S glycoprotein gene, the current Vietnamese PEDV isolates also showed high amino acid sequence homology ranging from 97.3-100% and were closely related to the Chinese isolates (JS-2004-2, DX) and the Thai isolates (07NP01, 08NP02, 08CB01) approximately 92.3-95.2% and 97.3-99.3% identity, respectively. In contrast, these current Vietnamese isolates had quite a lot of differences in genetic distance of amino acid sequences with those in Europe (CV777, Br1/87) and in Korea (Chinju99, Spk1, DR13, KNU-0801) at 85.6-87.9% and 80.0-93.8%. Likewise, the average percentages of peptide sequence homology of the Vietnamese PEDVs shared high relationship with the mentioned PEDVs in the neighboring countries including China, Korea and Thailand (Table 3) at 94.3%, 92.87% and 98.81%, respectively.

Full M gene: Homology of nucleotide and deduced amino acid sequences in full M gene of the current Vietnamese PEDV isolates shared considerably high homology (99.7-100% and 99.0-100%) to each other (Table 4). Similar to the partial S gene, the nucleotide and amino acid sequence homology were computed to make clearly the relationship among groups and within each group. Group 1 shared 97.89% and 96.18% in nucleotide and deduced peptide sequence identity, respectively, with group 2 and 97.33% and 95.09% with group 3 (Fig. 4). Within group 1, the current Vietnamese PEDV isolates shared 98.89% and 97.07% of nucleotide and amino acid sequence identity with the Thai isolates (07NP01, 08NP02, KU06RB08), 98.53% and 97.49% identity with the Chinese isolates (JS-2004-2, DX), and 98.56% and 96.71% identity with the recent Korean isolates (CPF299, M1763). Furthermore, the Thai isolates shared 98.24% and 96.97% of nucleotide and peptide

Table 2 Comparison between percent of homology of nucleotide and encoded amino acid sequences of the partial S gene of the southern Vietnamese PEDV isolates

	Br1/87	CV777	Spk1	Chinju99	DR13	KNU-0801	KNU-0802	JS-2004-2	DX	07NP01	08CB01	08NP02	VN92S1	VN94S2	VN97S3	VN103S4	VN109S5	VN112S6	VN122S8	VN116S7	
Br1/87	-	100	91.6	87.1	92.3	91.6	87.9	87.9	90.9	87.1	87.1	87.1	85.6	87.1	86.4	87.9	87.9	87.9	87.9	87.9	87.9
CV777	100	-	91.6	87.1	92.3	91.6	87.9	87.9	90.9	87.1	87.1	87.1	85.6	87.1	86.4	87.9	87.9	87.9	87.9	87.9	87.9
Spk1	96.9	96.9	-	90.9	95.9	100	93.1	91.6	93.1	90.1	90.1	90.1	88.6	91.6	90.9	90.9	90.9	90.9	90.9	90.9	90.9
Chinju99	94.2	94.2	95.3	-	86.4	90.9	83.2	81.6	84.8	81.6	81.6	81.6	80.0	83.2	82.4	82.4	82.4	82.4	82.4	82.4	82.4
DR13	97.9	97.9	97.5	93.8	-	95.9	93.8	94.5	95.9	92.3	92.3	92.3	90.9	92.3	91.6	93.1	93.1	93.1	93.1	93.1	93.1
KNU-0801	97.1	97.1	99.5	95.7	97.9	-	93.1	91.6	93.1	90.1	90.1	90.1	88.6	91.6	90.9	90.9	90.9	90.9	90.9	90.9	90.9
KNU-0802	96.5	96.5	97.2	92.9	97.6	97.4	-	94.5	95.9	94.5	94.5	94.5	91.6	93.1	92.3	93.8	93.8	93.8	93.8	93.8	93.8
JS-2004-2	96.6	96.6	96.2	92.0	97.9	96.3	98.2	-	97.3	95.9	95.9	95.9	93.1	94.5	93.8	95.2	95.2	95.2	95.2	95.2	95.2
DX	97.1	97.1	96.4	92.5	98.1	96.5	98.1	99.1	-	95.2	95.2	95.2	92.3	93.1	93.1	94.5	94.5	94.5	94.5	94.5	94.5
07NP01	96.4	96.4	95.8	92.2	97.5	95.9	98.1	99.1	98.6	-	100	100	97.3	98.6	98.0	99.3	99.3	99.3	99.3	99.3	99.3
08CB01	96.4	96.4	95.8	92.2	97.5	95.9	98.1	99.1	98.6	100	-	100	97.3	98.6	98.0	99.3	99.3	99.3	99.3	99.3	99.3
08NP02	96.4	96.4	95.8	92.2	97.5	95.9	98.1	99.1	98.6	100	100	-	97.3	98.6	98.0	99.3	99.3	99.3	99.3	99.3	99.3
VN92S1	95.6	95.6	95.0	91.4	96.8	95.1	97.1	97.8	97.7	98.8	98.8	98.8	-	97.3	98.0	98.0	98.0	98.0	98.0	98.0	98.0
VN94S2	96.2	96.2	95.9	92.4	97.4	96.0	97.6	98.4	97.9	99.3	99.3	99.3	98.9	-	99.3	99.3	99.3	99.3	99.3	99.3	99.3
VN97S3	96.1	96.1	95.7	92.2	97.2	95.9	97.5	98.2	97.8	99.2	99.2	99.2	99.1	99.9	-	98.6	98.6	98.6	98.6	98.6	98.6
VN103S4	96.4	96.4	95.8	92.2	97.5	95.9	97.8	98.5	98.1	99.5	99.5	99.5	99.1	99.9	99.7	-	100	100	100	100	100
VN109S5	96.4	96.4	95.8	92.2	97.5	95.9	97.8	98.5	98.1	99.5	99.5	99.5	99.1	99.9	99.7	100	-	100	100	100	100
VN112S6	96.4	96.4	95.8	92.2	97.5	95.9	97.8	98.5	98.1	99.5	99.5	99.5	99.1	99.9	99.7	100	100	-	100	100	100
VN122S8	96.4	96.4	95.8	92.2	97.5	95.9	97.8	98.5	98.1	99.5	99.5	99.5	99.1	99.9	99.7	100	100	100	-	100	100
VN116S7	96.4	96.4	95.8	92.2	97.5	95.9	97.8	98.5	98.1	99.5	99.5	99.5	99.1	99.9	99.7	100	100	100	100	-	100

Nucleotide identity (%) in lower triangle of table, Decoded amino acid identity (%) in upper triangle of table

Table 3 Comparison percent genetic distance (average % identity) of nucleotide/ deduced amino acid sequences of the partial S gene

PEDV strains	Group 1					Group 2	Group 3
	Europe	Korea	China	Thailand	Vietnam		
Group 1	Europe	-	97,21	96,85	96,40	96,24	
	Korea	90,11	-	98,10	97,80	97,51	
	China	90,85	95,19	-	98,85	98,18	96,20
	Thailand	87,10	93,41	95,54	-	99,35	92,72
Group 2						-	95,50
Group 3						90,90	-

Nucleotide identity (%) in upper triangle of table, Decoded amino acid identity (%) in lower triangle of table

sequence homology with the Chinese isolates, 98.95% and 97.74% identity with the recent Korean isolates. The Chinese and the recent Korean isolates shared 98.06% and 96.35% of nucleotide and decoded

aminoacid sequence identity, respectively. In particular, the Thai isolates had absolute homology of M gene with the recent Korean isolate (CPF299) at 100% identity. Similarly, the current Vietnamese

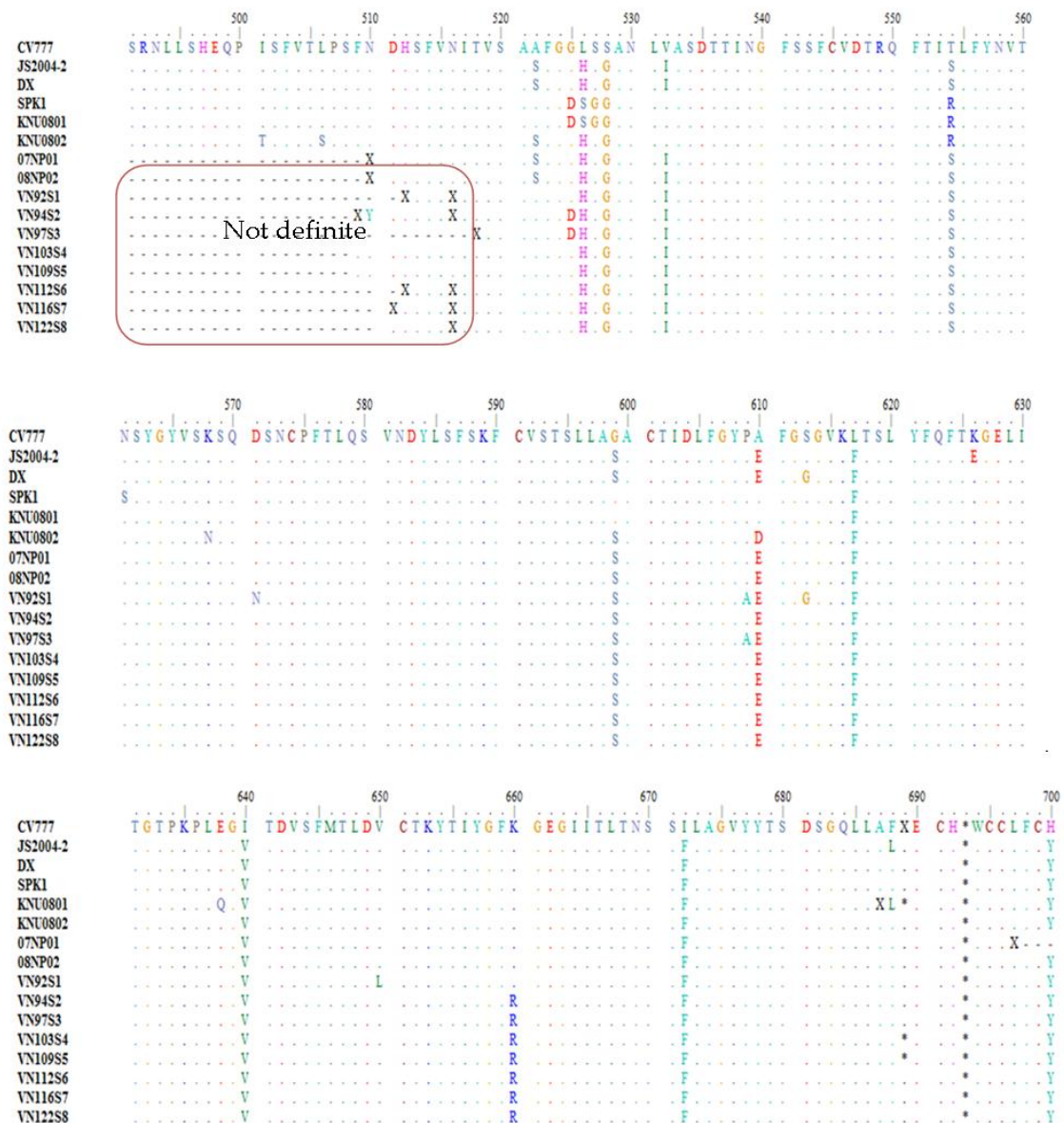

Figure 1 Comparison of encoded peptide sequence alignment of the partial S gene of eight Vietnamese PEDV isolates (VN92S1, VN94S2, VN97S3, VN103S4, VN109S5, VN112S6, VN116S7, VN122S8) and selected reference PEDV strains (European strains, CV777; Chinese isolates, JS-2004-2 and DX; Korean isolates, Spk1, KNU-0801, KNU-0802; Thai isolates, 07NP01, 08NP02). Dash (.) reveals the amino acid identity of isolates compare with prototype isolate (CV777). There were some sites in sequence with different encoded amino acids due to substitution of amino acids comparing with CV777.



Figure 2 Comparison of deduced amino acids sequence of the full M gene of six Vietnamese PEDV isolates (VN92M1, VN103M2, VN109M3, VN112M4, VN116M5, VN122M6) and selected reference PEDV strains (European strains, CV777 and Br1/87; Chinese isolates, JS-2004-2, LZC, DX and CHIMT06; Korean isolates, Chirju99, M1763, CPF299, KPEDV-09); Thai isolates, 07NP01, 08NP02 and KU06RB08). Dash (.) reveals the amino acid identity of isolates compare with prototype isolate (CV777). There were some sites in sequence with different amino acids due to substitution of amino acids comparing with CV777.

isolates had the closest relation with JS-2004-2 at 99.7% and 99.0% of nucleotide and decoded amino acid sequence identity, respectively.

Genetic characterization

Partial S gene: The nucleotide sequences of partial S gene of the southern Vietnamese PEDV isolates were composed of 600 nucleotides (encoded approximately 200 amino acids), located from position 1530 to 2130 in full length of S gene responding for epitope determinant of virus (data not shown) in which the nucleotide sequence revealed high variable sites from 1561 to 1600 and 1821 to 1851 (520 to 533 and 598 to 617 residues of amino acid sequence, respectively). There was a total 15 amino acids changes within 25 nucleotides substitution corresponding to the partial S gene (Fig 1).

Full M gene: The nucleotide sequence of the full M gene of the current Vietnamese PEDV isolates were composed of 687 nucleotides encoded approximately 225 amino acids. The six current Vietnamese PEDV isolates and the European prototype (CV777) revealed high homology containing 13 nucleotide changes corresponding to 2 residues substitution on amino acid sequences. Likewise, deduced amino acid of M gene shared extremely high homology among PEDV isolates of the neighboring countries of Asia (Fig. 2).

Phylogenetic analysis

Partial S gene: Phylogenetic analysis based on nucleotide and encoded amino acid sequences of the partial S gene revealed PEDV isolates divided into three groups (Fig. 3). Group 1 contained most of PEDV isolates in suffered countries including Europe (CV777, Br1/87), China (JS-2004, DX), Korea (DR13,

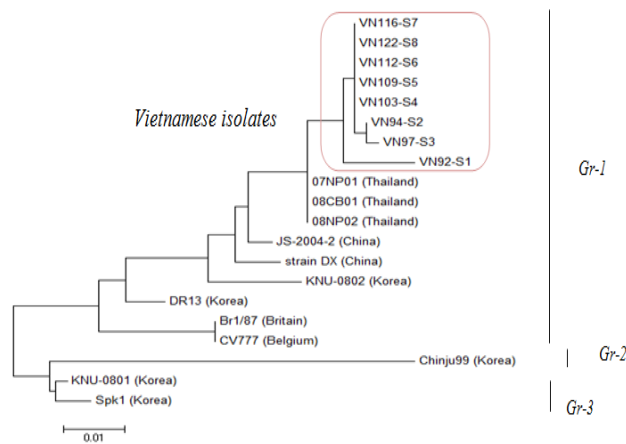

Figure 3 Dendrogram based nucleotide sequence of the partial S gene among eight southern Vietnamese PEDV isolates (VN92S1, VN94S2, VN97S3, VN103S4, VN109S5, VN112S6, VN116S7, VN122S8) with those of other reference strains (European strains, CV777 and Br1/87; Chinese isolates, JS-2004-2 and DX; Korean isolates, Chinju99, DR13, Spk1, KNU-0801, KNU-0802; Thai isolates, 07NP01, 08NP02, and 08CB01). Multiple alignment method performed by using ClustalX program. The scale bars indicate the number of 0.01 estimate evolutionary time.

KNU-0802), Thailand (07NP01, 08NP02, 08CB01) and Vietnam (in this study). Group 2 comprised Spk1, KNU-0801 (Korean isolates). Group 3 comprised previous Korean isolate (Chinju99). The current Vietnamese PEDV isolates dropped into a distinct clade compared with other reference isolates. They shared high homology. However, at least two separated clades in which clade 1 comprising VN94S2, VN97S3, VN103S4, VN109S5, VN112S6, VN116S7, VN122S8 and clade 2 containing only VN92S1 with 98.9% sequence identity were observed. It should be noted that the Vietnamese isolates contained high differences on the nucleotide sequence of the partial S gene with other prototypes in Europe (CV777, Br1/87) and in Korea (Chinju99, Spk1, KNU-0801). However, the current Vietnamese isolates, the Thai isolates, the Chinese isolates and the recent Korean isolate (KNU-0802) were clustered into the same subgroup on the phylogenetic tree.

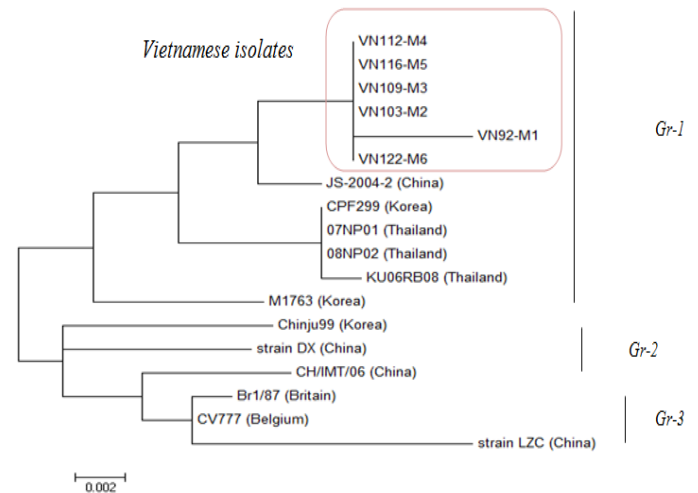

Figure 4 Dendrogram based on nucleotide sequence of the full M gene among six southern Vietnamese PEDV isolates (VN92M1, VN103M2, VN109M3, VN112M4, VN116M5, VN122M6) with those of other reference strains (European strains, CV777 and Br1/87; Chinese isolates, JS-2004-2, LZC, DX and CHIMT06; Korean isolates, Chinju99, M1763, CPF299; Thai isolates, 07NP01, 08NP02 and KU06RB08). Multiple alignment method performed by using ClustalX program. The scale bars indicate the number of 0.002 estimate evolutionary time.

Full M gene: PEDVs were similarly divided into three distinct genetic groups (Fig 4). Group 1 comprised the Vietnamese isolates (in this study), the Chinese isolate (JS-2004-2), the recent Korean isolates (CPF299, M1763) and the Thai isolates (07NP01, 08NP02, KU06RB08). The current Vietnamese PEDV isolates had close relationship with the mentioned above recent isolates from Asian countries including China (JS-2004-2), Thailand (07NP01, 08NP02, KU06RB08), and Korea (CPF299) clustering into a separated subgroup in phylogenetic tree. Group 2 comprised Chinju99 (Korea), DX and CHIMT06 (China). Group 3 included CV777, Br1/87 (Europe) and LZC (China).

Table 4 Comparison between percent of homology of nucleotide and encoded amino acid sequences of full M gene of the southern Vietnamese PEDV isolates

	Br1/87	CV777	Chinju99	CPF299	M1763	LZC	DX	CHIMT06	JS-2004-2	07NP01	KU06RB08	08NP02	VN92M1	VN103M2	VN109M3	VN112M4	VN116M5	VN122M6
Br1/87	-	99,5	97,9	95,3	96,4	96,9	96,4	97,4	95,8	95,3	94,8	95,3	94,8	95,8	95,8	95,8	95,8	95,8
CV777	100	-	98,5	95,8	96,9	97,4	96,9	97,9	96,4	95,8	95,3	95,8	95,3	96,4	96,4	96,4	96,4	96,4
Chinju99	99,7	99,7	-	95,3	96,4	95,8	96,4	97,4	95,83	95,3	94,8	95,3	94,76	95,8	95,8	95,8	95,8	95,8
CPF299	97,2	97,2	97,5	-	95,8	93,1	95,8	95,8	98,5	100	99,5	100	96,4	97,4	97,4	97,4	97,4	97,4
M1763	98,6	98,6	98,3	97,9	-	94,2	94,8	95,8	96,4	95,8	95,3	95,8	95,3	96,4	96,4	96,4	96,4	96,4
LZC	99,3	99,3	99,0	96,4	97,9	-	94,2	95,3	93,7	93,1	92,6	93,1	92,6	93,7	93,7	93,7	93,7	93,7
DX	98,6	98,6	99,0	97,2	97,2	97,9	-	97,9	97,4	95,8	95,3	95,8	95,3	96,4	96,4	96,4	96,4	96,4
CHIMT06	99,7	99,7	99,3	97,5	98,3	99,0	99,0	-	97,4	95,8	95,3	95,8	96,4	97,4	97,4	97,4	97,4	97,4
JS-2004-2	97,9	97,9	98,3	99,3	98,6	97,2	97,9	98,3	-	98,5	97,9	98,5	97,9	99,0	99,0	99,0	99,0	99,0
07NP01	97,2	97,2	97,5	100	97,9	96,4	97,2	97,5	99,3	-	99,5	100	96,4	97,4	97,4	97,4	97,4	97,4
KU06RB08	97,2	97,2	97,5	100	97,9	96,4	97,2	97,5	99,3	100	-	99,5	95,8	97	96,9	96,9	96,9	96,9
08NP02	97,2	97,2	97,5	100	97,9	96,4	97,2	97,5	99,3	100	100	-	96,4	97,4	97,4	97,4	97,4	97,4
VN92M1	97,2	97,2	97,5	98,6	97,9	96,4	97,2	97,5	99,3	98,6	98,6	98,6	-	99,0	99,0	99,0	99,0	99,0
VN103M2	97,5	97,5	97,9	99,0	98,3	96,8	97,5	97,9	99,7	99,0	99,0	99,0	99,7	-	100	100	100	100
VN109M3	97,5	97,5	97,9	99,0	98,3	96,8	97,5	97,9	99,7	99,0	99,0	99,0	99,7	100	-	100	100	100
VN112M4	97,5	97,5	97,9	99,0	98,3	96,8	97,5	97,9	99,7	99,0	99,0	99,0	99,7	100	100	-	100	100
VN116M5	97,5	97,5	97,9	99,0	98,3	96,8	97,5	97,9	99,7	99,0	99,0	99,0	99,7	100	100	100	-	100
VN122M6	97,5	97,5	97,9	99,0	98,3	96,8	97,5	97,9	99,7	99,0	99,0	99,0	99,7	100	100	100	100	-

Nucleotide identity (%) in lower triangle of table;

Decoded amino acid identity (%) in upper triangle of table

Discussion

Porcine epidemic diarrhea virus (PEDV) is classified into genetic group 1 of Coronaviruses. Spike (S) glycoprotein and membrane (M) glycoprotein genes are believed to have genetic variation geographically (Britton et al., 1991; Cavanagh et al., 1992; Adzhar et al., 1995; Ballesteros et al., 1997; Leparç-Goffart et al., 1997; Kingham et al., 2000; Saif, 2004; Weiss and Navas-Martin, 2005). Moreover, the heterogeneity in those genomic sequences has been reported and is known essentially for the diverse PEDV pathogenicity (Lai et al., 2007; Lee et al., 2010). PEDV genome is considered to have a diversity based on previous studies (Kweon et al., 1999; Kocherhans et al., 2001; Yeo et al., 2003; Jinghui and Yijing, 2004; Junwei et al., 2006; Park et al., 2007^b; Li et al., 2009; Puranaveja et al., 2009; Lee et al., 2010). The genetic regions of nucleotide sequence containing the highest variations are C-terminal and N-terminal regions of S1 domain which are used to analyze genetic relationship among PEDVs in this study (Park et al., 2007^b; Lee et al., 2010). The M gene of Coronaviruses seems to be more conservable than the S gene (Lai et al., 2007; Chen et al., 2008; Puranaveja et al., 2009). The important role of M gene contributes to the assembly of process of viral nucleocapsid and membrane of internal structure as well as to the interferon secretion stimulation (Lai et al., 2007). The phylogenetic analysis showed the close relationship among isolates of neighboring countries in group 1 in China (JS-2004-2, DX), in Korea (KNU-0802, CPF299, and M1763), in Thailand (07NP01, 08NP02, 08CB01, KU06RB08) and in Vietnam. Particularly, Vietnamese PEDV isolates are extremely related to JS-2004-2 and the Thai isolates are absolutely related to the Korean isolate (CPF299) with 100% nucleotide and amino acid identity of M gene. These evidences suggests that the Chinese-like isolates have been responsible for the recent Asian outbreaks prevailing in Korea, Thailand and Vietnam (Park et al., 2007^b; Puranaveja et al., 2009; Lee et al., 2010). Interestingly, geographic risk

factor seem to play a minor role in this PED outbreak similar to the outbreaks in Thailand and Korea since the outbreak occurred first in the southern part of Vietnam faraway from China. In addition, animal movement among those countries is limited. Other risk factors including poor bio-security application on fomites, animals and humans may play a major impact in the disease outbreak among those affected countries.

Within the eight southern Vietnamese PEDV isolates, there was a small difference in VN92S1 compared with other Vietnamese isolates since it was isolated from a different farm and a different province (Farm 1, Binhduong). Two other isolates (VN94S4, VN97S3) collected from another farm in Binhduong also revealed minor differences in nucleotide and amino acid sequence with the other isolates. Therefore, the isolates from Binhduong were grouped into a distinct sub-cluster demonstrating that the current PEDV isolates have gradually had genetic diversity.

In conclusion, the phylogenetic analysis indicated that these current Vietnamese PEDV isolates have originated from the same Chinese ancestor and they were gradually undergoing genetic variation and forming a new PEDV sub-cluster in Vietnam. Furthermore, these results suggested that the Chinese isolates (JS-2004-2) could be the ancestor of the current PEDV outbreaks transmitting to the neighboring countries of Asia including Korea, Thailand and Vietnam (Park et al., 2007^b; Chen et al., 2008; Puranaveja et al., 2009). It should be noted that the epidemiology of PED outbreaks is commonly related to geographic influence by transmission and circulation of the causative agent among neighboring countries. Since emerging in Europe, PED outbreaks have been worldwide spread to many geographical areas but not in the American continents excepting an old report of PED-induced outbreak in Canada (Turgeon et al., 1980). The reasons explained for the

absence of PED in Americas might be the geographical separation from the arising places of emerging virus and the availability of good preventive strategies in those countries. In addition, no animal movement from the PEDV endemic areas has been introduced into the North American continent. Normally, movement of live pigs, breeding stocks supplying for commercial farms and human movement among the countries could be major risk factors for the transmission of any emerging disease. In the current Vietnamese PED outbreaks, poor biosecurity application on fomites, animals and humans were considered main risk factors. Spreading among neighboring farms after the first introduction in the area is mostly due to animal and human movement as well as contaminated vehicles. Therefore, the clear elucidation of the origin and transmitted route of this emerging PEDV may contribute to a better understanding on the epidemiology and finally to effective prevention and control of the disease.

Acknowledgement

The authors would like to thank "The Graduate Scholarship Program for Faculty Member for Neighboring Countries" for giving Mr. Do Tien Duy an opportunity to further his MSc study at the Veterinary Pathobiology program, Chulalongkorn University. We are also grateful to Dr. Nguyen Tat Toan, lecturer of Nonglam University, Vietnam and Mr. Keatipong Mongkolwit, officer of C.P. Vietnam Livestock Corporation for their assistance in collecting samples.

References

- Adzhar, A.B., Shaw, K., Britton, P. and Cavanagh, D. 1995. Avian infectious bronchitis virus: Differences between 793/B and other strains. *Vet Rec.* 136(21): 548.
- Ballesteros, M.L., Sanchez, C.M. and Enjuanes, L. 1997. Two amino acid changes at the N-terminus of transmissible gastroenteritis Coronavirus spike protein result in the loss of enteric tropism. *Virology*. 227(2): 378-388.
- Britton, P., Mawditt, K.L. and Page, K.W. 1991. The cloning and sequencing of the virion protein genes from a British isolate of porcine respiratory Coronavirus: Comparison with transmissible gastroenteritis virus genes. *Virus Res.* 21(3): 181-198.
- Cavanagh, D., Davis, P.J., Cook, J.K.A., Li, D., Kant, A. and Koch, G. 1992. Location of the amino acid differences in the S1 spike glycoprotein subunit of closely related serotypes of infectious bronchitis virus. *Avian Pathol.* 21(1): 33-43.
- Chen, J.F., Sun, D.B., Wang, C.B., Shi, H.Y., Cui, X.C., Liu, S.W., Qiu, H.J. and Feng, L. 2008. Molecular characterization and phylogenetic analysis of membrane protein genes of porcine epidemic diarrhea virus isolates in China. *Virus Genes.* 36(2): 355-364.
- Duarte, M. and Laude, H. 1994. Sequence of the spike protein of the porcine epidemic diarrhea virus. *J Gen Virol.* 75(5): 1195-1200.
- Jinghui, F. and Yijing, L. 2004. Cloning and sequence analysis of the M gene of porcine epidemic diarrhea virus LJB/03. *Virus Genes.* 30(1): 69-73.
- Junwei, G., Baoxian, L., Lijie, T. and Yijing, Li. 2006. Cloning and sequence analysis of the N gene of porcine epidemic diarrhea virus LJB/03. *Virus Genes.* 33(2): 215-219.
- Kang, T.J., Seo, J.S., Kimb, D.H., Kim, T.G., Jang, Y.S. and Yang, M.S. 2005. Cloning and sequence analysis of the Korean strain of spike gene of porcine epidemic diarrhea virus and expression of its neutralizing epitope in plants. *Protein Expr Purif.* 41(2): 378-383.
- Kingham, B.F., Keeler, C.L., Nix, W.A., Ladman, B.S. and Gelb, J.J. 2000. Identification of avian infectious bronchitis virus by direct automated cycle sequencing of the S-1 gene. *Avian Dis.* 44(2): 325-335.
- Kocherhans, R., Bridgen, A., Ackermann, M. and Tobler, K. 2001. Completion of the porcine epidemic diarrhea Coronavirus (PEDV) genome sequence. *Virus Genes.* 23(2): 137-144.
- Kweon, C.H., Kwon, B.J., Lee, J.G., Kwon, G.O. and Kang, Y.B. 1999. Derivation of attenuated porcine epidemic diarrhea virus (PEDV) as vaccine candidate. *Vaccine.* 17(20): 2546-2553.
- Lai, M.M., Perlman, S. and Anderson, L.J. 2007. Coronaviridae. In: *Fields Virology*. 5th ed. D.M. Knipe and P.M. Howley (eds.) Massachusetts: Lippincott Williams & Wilkins. 1306-1332.
- Lepar-Goffart, I., Hingley, S.T., Chua, M.M., Jiang, X., Lavi, E. and Weiss, S.R. 1997. Altered pathogenesis of a mutant of the murine Coronavirus MHV-A59 is associated with a Q159L amino acid substitution in the spike protein. *Virology*. 239(1): 1-10.
- Lee, D.K., Park, C.K., Kim, S.H. and Lee, C. 2010. Heterogeneity in spike protein genes of porcine epidemic diarrhea viruses isolated in Korea. *Virus Res.* 149(2): 175-182.
- Li, J.Q., Liu, J.X., Lan, X., Cheng, J., Wu, R., Lou, Z.Z., Yin, X.P., Li, X.R., Li, B.Y., Yang, B. and Li, Z.Y. 2009. Cloning the structure genes and expression the N gene of porcine epidemic diarrhea virus DX*. *Virology Sinica.* 24(3): 179-186.
- Park, S.J., Song, D.S., Ha, G.W. and Park, B.K. 2007^a. Cloning and further analysis of the spike gene of attenuated porcine epidemic diarrhea virus DR13. *Virus Genes.* 35(1): 55-64.
- Park, S.J., Moon, H.J., Yang, J.S., Lee, C.S., Song, D.S., Kang, B.K. and Park, B.K. 2007^b. Sequence analysis of the partial spike glycoprotein gene of porcine epidemic diarrhea viruses isolated in Korea. *Virus Genes.* 35(2): 321-332.
- Pensaert, M.B. and Yeo, S.G. 2006. Porcine epidemic diarrhea. In: *Diseases of swine*. 9th ed. B.E. Straw, J.J. Zimmerman, S.D'Allaire. and D.J. Taylor (eds) Oxford: Wiley-Blackwell. 367-372.
- Puranaveja, S., Poolperm, P., Lertwatcharasarakul, P., Kesdaengsakonwut, S., Boonsoongnern, A., Urairong, K., Kitikoon, P., Choojai, P., Kedkovid, R., Teankum, K. and Thanawongnuwech, R. 2009. Chinese-like strain of porcine epidemic diarrhea virus, Thailand.

- Emerg Infect Dis. 15(7): 1112-1115.
- Saif, L.J. 2004. Animal Coronaviruses: what can they teach us about the severe acute respiratory syndrome?. *Rev Sci Tech.* 23(2): 643-660.
- Saitou, N. and Nei, M. 1993. Estimation of the number of nucleotide substitutions in the control region of mitochondrial DNA in humans and chimpanzees. *Mol Biol Evol.* 10: 512-526.
- Tamura, K., Dudley, J., Nei, M. and Kumar, S. 2007. MEGA4: Molecular evolutionary genetics analysis software version 4.0. *Mol Biol Evol.* 24(8): 1596-1599.
- Turgeon, D.C., Morin, M., Jolette, J., Higgins, R., Marsolais, G. and DiFranco, E. 1980. Coronavirus-like particles associated with diarrhea in baby pigs in Quebec. *Can Vet J.* 21(3): 100-xxiii.
- Weiss, S.R. and Navas-Martin, S. 2005. Coronavirus pathogenesis and the emerging pathogen severe acute respiratory syndrome Coronavirus. *Am Soc Micro.* 69(4): 635-664.
- Yeo, S.G., Hernandez, M., Krell, P.J. and Nagy, E. 2003. Cloning and sequence analysis of the spike gene of porcine epidemic diarrhea virus Chinju99. *Virus genes.* 26(3): 239-246.

